

# Dealer Manual

## Installation Supplement

# **AMERICAN "PERC-RITE<sup>®</sup>"**

**"QM"** - *QUALITY MONITORING*

**SEMI-AUTOMATIC** - 1 ZONE SIMPLEX FOR ENCLOSED VALVE BOX

PATENT NOS. 5,200,065 - 5,984,574 - 6,262,689

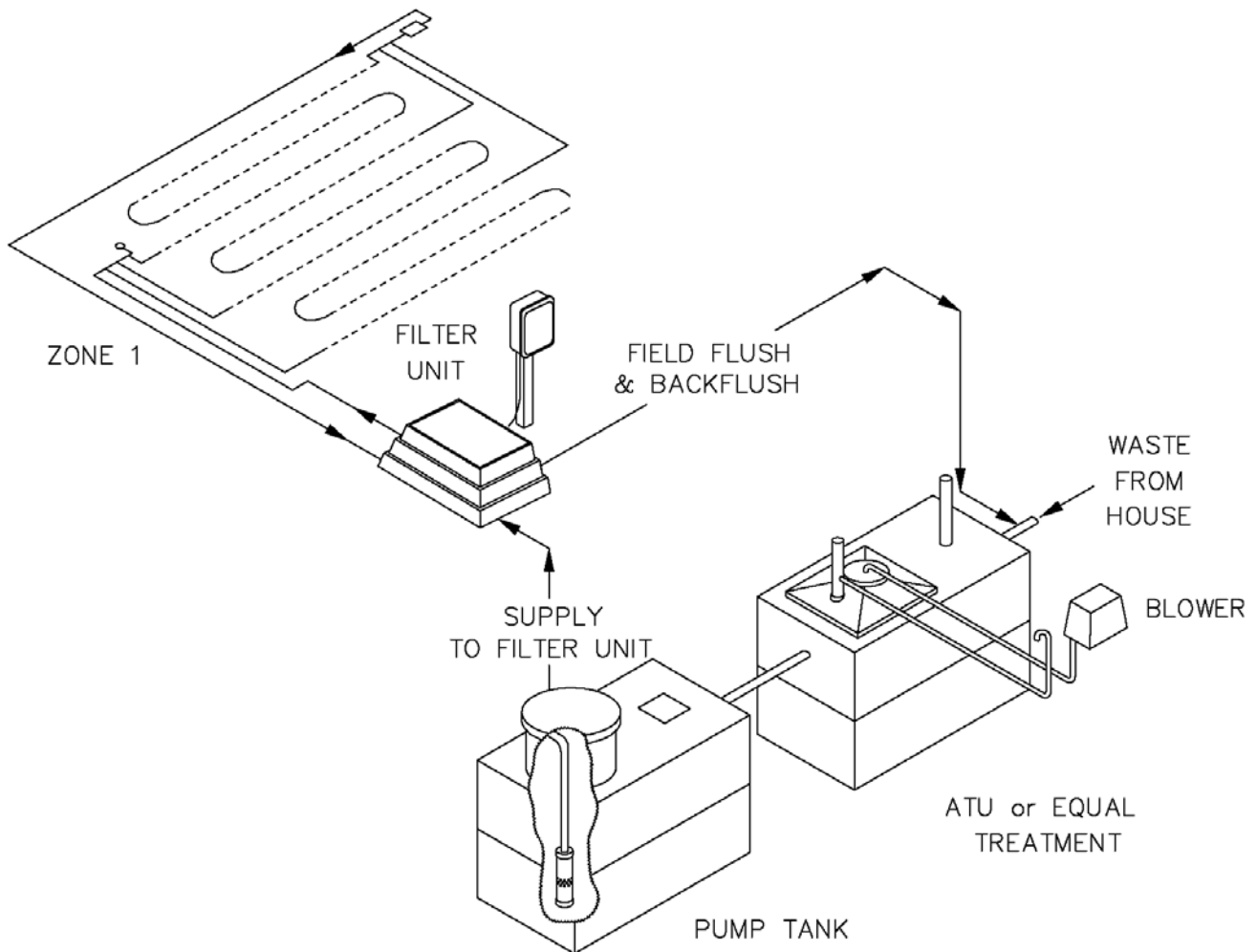

MANUFACTURED BY:  
**AMERICAN MANUFACTURING COMPANY INC.**  
P.O. Box 97, Elkwood, VA 22718  
1-800-345-3132

## Table of Contents

Cover	1
Table of Contents	2
IMPORTANT NOTICE	2
Dealer Responsibility	3
Pump Chamber & Hydraulic Unit Details	4
Installation Procedure Summary	8
Data Registers & Component Specifications & Details	9
Control Panel Installation Schematics	12
Startup Procedures	14
Operational Checklist	17
Order Information & Sales PR Page	18

## IMPORTANT NOTICE

This Dealer Manual is intended to give general information and guidance to authorized dealers and other qualified installers. The installer must determine the suitability of an American Manufacturing Company Drip Dispersal System for sewage disposal regarding basic design and layout and how the system functions in a specific site. The final decision as to the suitability of a system must be made by the designer. Suitability should be based on consideration of the general standards and information contained herein as well as other applicable waste disposal reference materials, specific topography, soil characteristics, space limitations, and other factors associated with a particular project. Consequently, American Manufacturing Company, Inc., a Virginia corporation, shall not be held liable in any manner to design engineers and other designers or installers of sewage disposal systems for claims arising from the use of the information contained herein nor actions arising from the reliance upon the accuracy of such information.

Additionally, unless American Manufacturing Company, Inc. or its employees are primarily responsible for a particular project, American Manufacturing Company, Inc. assumes no responsibility regarding, and shall not be liable to, any purchaser of a System in any manner for any of the following:

- a. any decision regarding the suitability of a Drip Dispersal System
- b. the design and/or installation of a Drip Dispersal System for any particular project, nor
- c. the utility or functioning of a Drip Dispersal System for the project.

Purchaser's rights are set forth in the limited warranty and the Equipment Purchase Contract (invoice) in the event that the equipment itself is defective.

By acceptance of this Manual, every recipient acknowledges that the material contained herein is copyrighted. The distribution and dissemination of this Manual in any form, including without limitation, printed or electronic media, is reserved solely to the discretion of American Manufacturing Company, Inc. and its authorized agents. Unauthorized reproduction and distribution of the information contained herein is strictly prohibited. The information contained herein may be modified periodically by American Manufacturing Company, Inc. without any prior or subsequent notification being given or obligated to be given to any recipient of this Manual. The recipient of this Manual is responsible for ascertaining whether his or her manual is the most recent version available.

## DEALER RESPONSIBILITY

### PURPOSE

The purpose of this section is to outline the responsibilities of the Dealer regarding the installation, monitoring, maintenance and warranty of the drip dispersal system as part of an on-site sewage treatment system.

### INSTALLERS SCHEDULE OF DUTIES

1. The Dealer shall be responsible for the entire installation and shall only sell and install systems according to approved plans and permits.
2. The Dealer shall be responsible for insuring proper electrical installation and startup including recording startup date and initial meter readings.
3. The Dealer will meet standards for operation and maintenance per the jurisdictional health department.
4. The Dealer shall assure that all employees who work on the American Drip System are trained, understand and can perform operation and maintenance per the Drip System manufacturer manuals.
5. The Dealer is responsible for informing the owner within the first month of operation of the type of system installed and the owners responsibilities.
6. The Dealer is responsible for the first annual inspection after the 3rd month of operation.
7. The Dealer is responsible for one visit after first year of operation. The visit to include the following;
  - Sludge Judge the septic tank blanket
  - Inspect the drip system hardware for operation
  - Inspect system with operational checklist
  - Check landscaping for interference with system
  - Check water usage and evaluate usage compared to design

The inspection frequency should be set based on the first year's evaluation. Future inspections should be at a minimum once per year. If high strength waste is suspect, take sample for BOD,SS, and FOG.

8. Removal, replacement or alteration to this system must be in compliance with all applicable current county health department requirements, governing sewage treatment regulations and the manufacturer.

### OWNER'S RESPONSIBILITIES

1. Acknowledge receipt and comply with instructions of the owner's manual provided. Reference owner's responsibilities in manual.
2. Notifying the Dealer or the designated agent immediately of any problems with the sewage treatment system.
3. Keeping the monitoring / access covers free of obstructions at all times.
4. Granting Installer / Operator and health department personnel access to the owner's property to service or inspect the sewage treatment system at any time during warranty period.
5. If system fails, owner will notify operator, manufacturer, and local health department.
6. Pumping the septic tank or other costs associated with the treatment system is not covered under any warranty. Pumping is required from time to time (frequency) varies by jurisdiction just like in conventional systems due to the production of solids during the treatment process.
7. Failure to make any payments when due shall be considered a breach of warranty and the operator may terminate warranty work without notice.

## **Specifications**

**DISC FILTERS** - Disc Filters shall be an oblique filter, entirely of plastic, with two 3/4" male end connections to NPT schedule 40 pressure PVC. The filter elements shall consist of grooved rings, mounted on a spine, forming a cylindrical filter body. The rings are to be kept together by a spring seated at the bottom of the filter cover. The out-in filter shall be of the screw in type with nitrilic rubber o-ring seal. The body materials shall be polyester, the spine and rings shall be polypropylene, and the spring shall be stainless steel. The nominal filtration capacity of the filter shall be 115 microns.

**DRIPPER TUBING** - The dripper tubing shall be pressure compensating dripperline for wastewater. The tubing shall be nominal 0.61 gallons per hour (+/- 5% flow rate from 7 to 60 psi). The tubing shall function as a turbulent flow emitter between 0 and 7 psi, ensuring that the nominal design flow is not exceeded at system start-up. The tubing shall be polyethylene 120 psi rating. Tubing end connections and splice connections shall be manufactured specifically for the tubing and for connection to standard schedule 40 NPT adapters.

**AUTOMATIC CONTROL VALVES** - The automatic control valves shall be solenoid activated diaphragm valves. The body and cover shall be reinforced nylon. The metal parts shall be stainless steel, the diaphragm shall be nylon-fabric reinforced poly isoprene. The seals shall be Buna-N. These valves shall operate electrically using hydraulic pressure to open and to close.

**RETURN PRESSURE ASSEMBLY FOR ZONE RETURN CONTROL VALVE** - The automatic zone return valve shall, in the event the drip zones are over 8 feet in vertical elevation above the hydraulic unit, have installed a "return pressure assembly". The assembly is to be used to prevent the line from draining after or during each dose. See standard detail.

**GRAVITY PIPING** - All gravity piping shall be schedule 40 PVC DWV as a minimum. Fittings shall be Schedule 40 PVC suitable for underground installation. All joints shall be solvent welded with the use of primer and PVC Glue.

**NON-DRIPPER LINE PRESSURE PIPING** - All non-dripper line pressure piping shall be PVC schedule 40 pressure rated. Rigid piping shall be standard ASTM 1120 for use with solvent welded Schedule 40 fittings. Flex piping shall be schedule 40 PVC flex pipe for use with pressure fittings.

**FLEX TUBING** - All non-dripper flexible tubing shall be standard IPS flex vinyl (pvc) pipe which shall be readily assembled to standard Schedule 40 PVC fittings and/or rigid Schedule 40 PVC pipe. All joints shall be solvent welded with the use of PVC primer and PVC Glue. Flex tubing shall be nominal 1/2" dia. (0.84" O.D.) PVC IPS hose.

**FLOAT SWITCHES** - Float switches for level indication and control shall be encapsulated mercury or mechanical differential switches. The switches shall be provided by American Manufacturing, or equal.

**GENERAL VALVES** - All gate, ball, globe and check valves shall be Schedule 40. Check valves shall be of the swing check design of metallic bronze with corrosion resistant metal hinge pin for use in wastewater.

**PIPING DISCONNECTS** - Piping disconnects shall be PVC schedule 80 unions.

**AIR RELEASE VALVES** - Air release valves shall be resilient seat "pop-up" type air release valves for use with filtered effluent (nominal filtration size of 115 microns.)

**WIRE SPLICES** - Field wire splices shall be installed in suitable wire splice pull boxes with waterproof connections for access to splice connections. The boxes shall have structural capacity for in ground installation and light vehicle yard care traffic.

**SPECIAL DRIP EQUIPMENT** - All non-specified drip equipment shall be as supplied by American Manufacturing Company, Inc. including the controls, drip hydraulic unit, pumps, and specialty fittings.

**PIPE BEDDING** - In ground piping shall be installed according to local codes. Piping shall be installed on original soil or suitably compacted fill or gravel bedded excavations on original soil. Free standing piping shall be schedule 40 PVC and assembled with restrained joints.

# STANDARD DETAILS

## REMOTE ZONE VALVE

The remote zone valves are typically used on larger systems with more than four zones or when the zones are below the elevation of the pump chamber. On slopes greater than 5% a bentonite clay plug should be installed three feet up contour from the valve box to prevent effluent from piping down the manifold and filling the valve box.

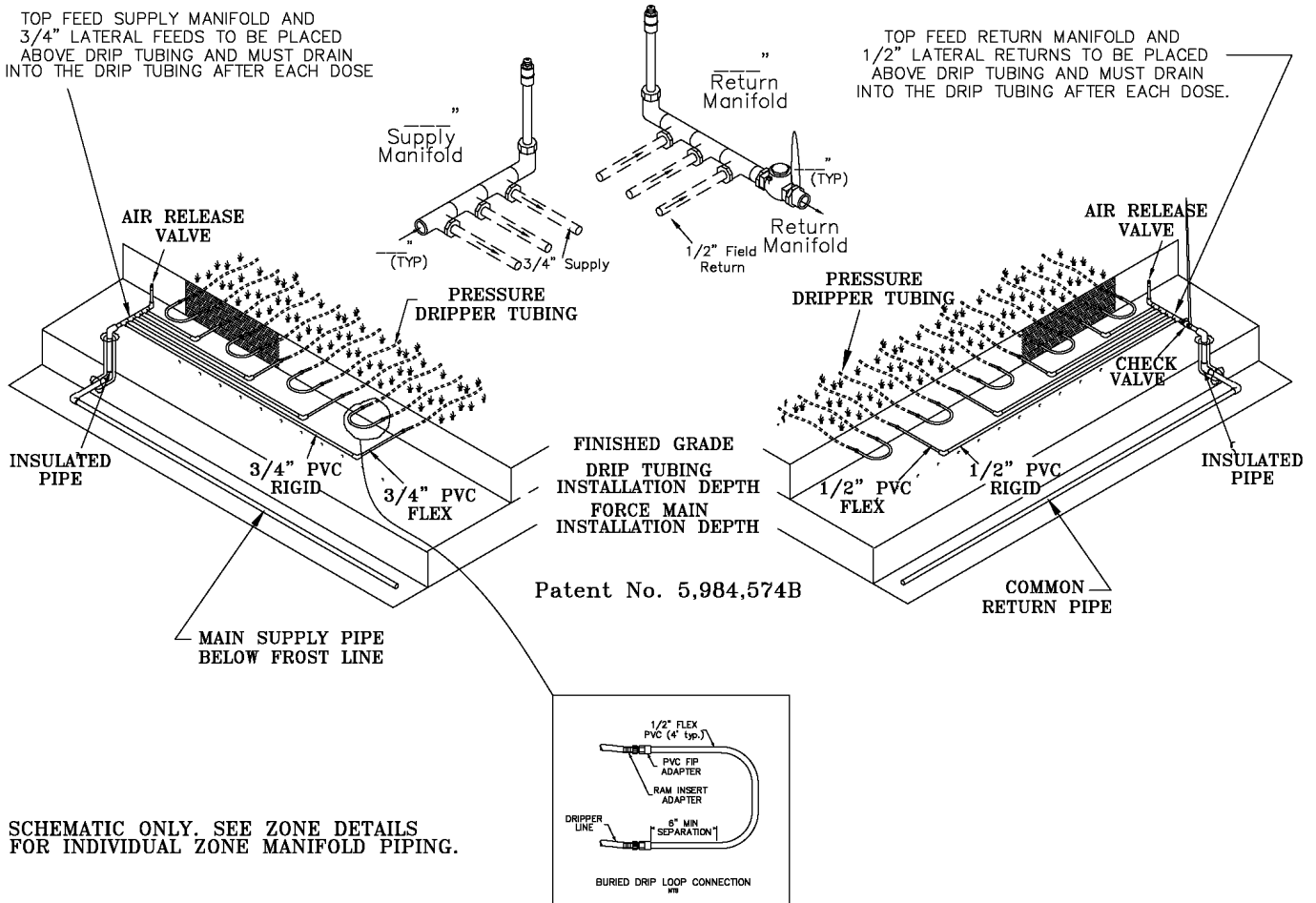

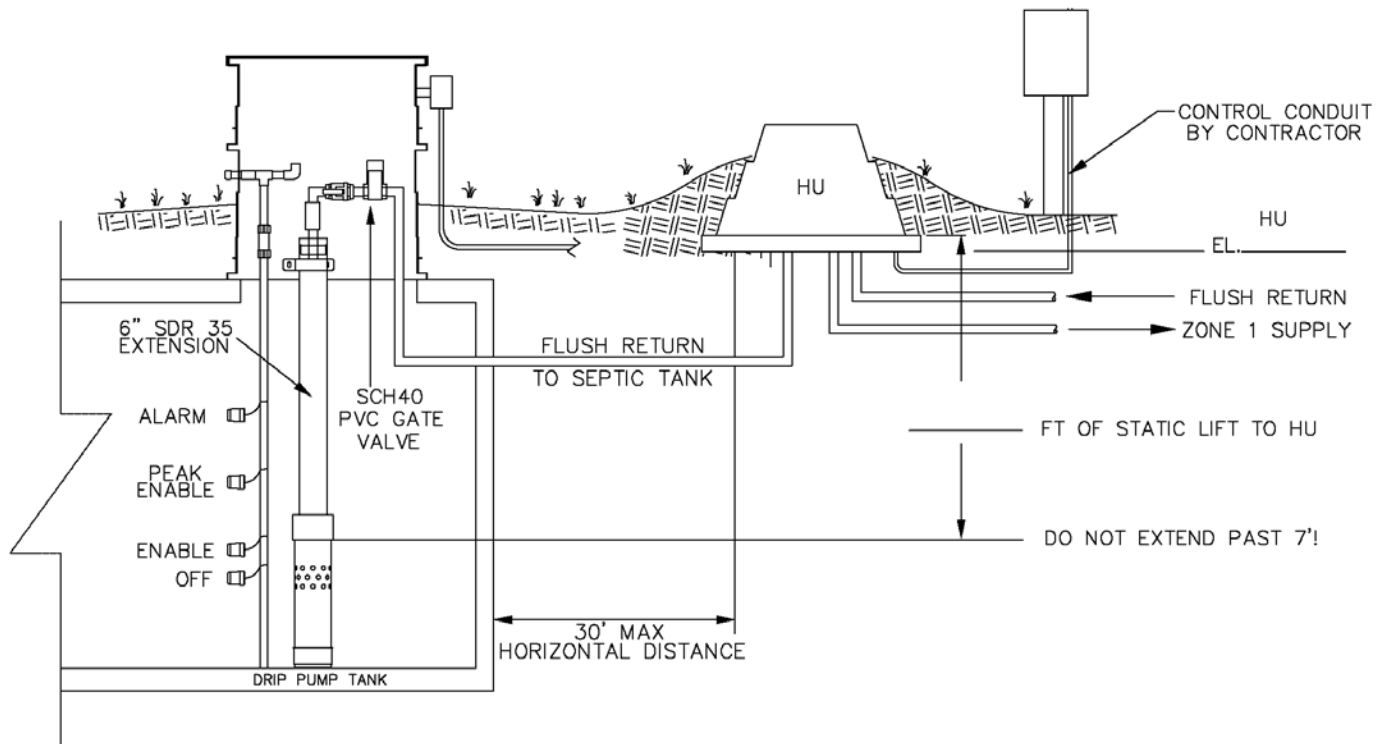

### Perc-Rite® Valve Box Filtration System and Pump Chamber Installation

The Filtration system must be close to the pump chamber as shown. The limiting factor is the backflushing sequence for the disc filters. The Filtration system must be within 30 feet horizontal and 8 feet vertical distance for the pump to have enough TDH to complete backflushing.

The return line to the septic tank must have gravity flow back to the septic tank. The 1-1/2" line must have a 2% slope to drain back or a check valve should be placed at the (HU) to prevent backpressure on the backflush valves. If longer distances are used, the line size should be increased to 2".

The pump should be placed as shown, secured on the floor of the pump tank. The pump discharge pipe must have **NO WEEP HOLE**. The pump is to be hard wired into a junction box.

1. Recommend half to full day storage between drip enable and high level alarm.
2. Recommend at least one-quarter day storage between alarm and inlet of tank.
3. Peak flow dispersal will be in use when the float switch is installed and in the up position.
4. Install pump and floats as shown. The pump must NOT be installed with a weep hole due to the high pressure. Pump must be "hard wired" to maintain warranty. A disconnect should be provided next to a suitable outdoor rated junction box.
5. Dig a side trench to set the hydraulic unit. The area must be free from groundwater or rainwater infiltration. (If below original grade more than 4" the unit enclosure must have a positive drain.) Center the unit on a gravel bed with the pipes slightly over the edge. Connect the supply and return piping. Install the control panel on a 4"x4" (minimum) pressure treated post with at least 3 feet of clearance from the bottom of the control panel to the ground. The electrician shall provide three sources of power to the control panel per the schematic enclosed in the control enclosure. The control wire shall be run through conduit to the control with no splices and connected to the terminal strip provided. Connect the heater, floats and pump(s) to the control panel.
6. Install the insulated enclosure and backfill the area making sure not to damage any piping or electrical components. Provide positive drainage from around the central unit to insure no excessive rainwater will enter and rainwater which does enter will drain out. Provide a minimum of 4" of backfill above the bottom edge of the enclosure to help enclosure heater maintain temperatures above freezing. Additional mounding is preferred for freeze protection and aesthetics.

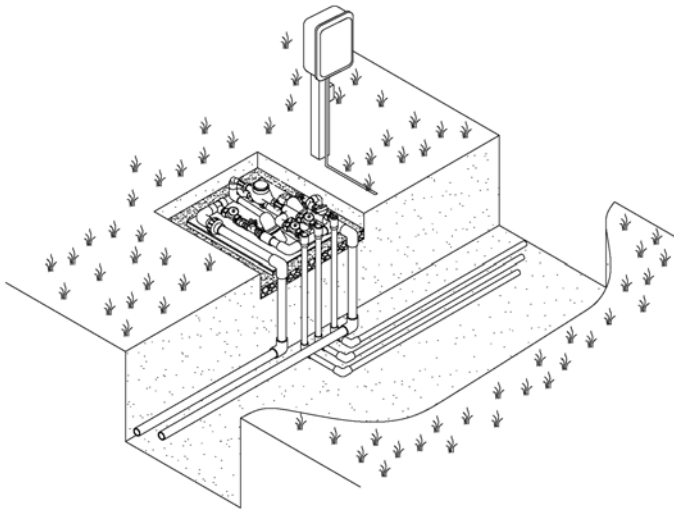

**STEP 1**

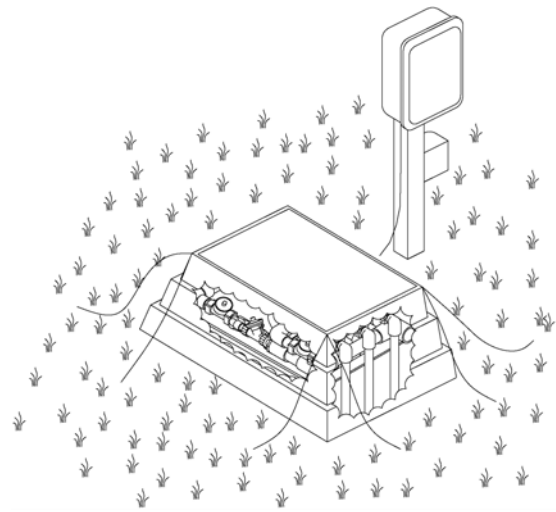

**STEP 2**

### **Perc-Rite® Insert Filtration System and Pump Chamber Installation**

The Filtration system is attached to the pump chamber riser as shown. The return line to the septic tank must have gravity flow back to the treatment tank. The 1-1/2" line must have a 2% slope to drain back or a check valve should be placed at the filter unit to prevent backpressure on the backflush valve. If longer distances are used, the line size should be increased to 2".

The pump should be placed as shown, secured on the floor of the pump tank. The pump discharge pipe must have **NO WEEP HOLE**. The pump is to be hard wired into a junction box.

1. Recommend half to full day storage between drip enable and high level alarm.
2. Recommend at least one-quarter day storage between alarm and inlet of tank.
3. Peak flow dispersal will be in use when the float switch is installed and in the up position.
4. Install pump and floats as shown. Install using a 6" SDR 35 coupling and riser (by others). The pump must NOT be installed with a weep hole due to the high pressure. Pump must be "hard wired" to maintain warranty. A disconnect should be provided next to a suitable outdoor rated junction box.
5. Dig a trench to set the flow meter and return valve. The area must be free from groundwater or rainwater infiltration. It should be deep enough to prevent freezing. (If below original grade more than 4" the unit enclosure must have a positive drain.) Center the components on a gravel bed. Connect the supply and return piping. Install the control panel on a 4"x4" (minimum) pressure treated post with at least 3 feet of clearance from the bottom of the control panel to the ground. The electrician shall provide two sources of power to the control panel per the schematic enclosed in the control enclosure. The control wire shall be run through conduit to the control with no splices and connected to the terminal strip provided. Connect the floats and pump(s) to the control panel.
6. Install the enclosure and backfill the area making sure not to damage any piping or electrical components. Provide positive drainage from around the central unit to insure no excessive rainwater will enter and rainwater which does enter will drain out. Provide a minimum of 4" of backfill above the bottom edge of the enclosure to help enclosure heater maintain temperatures above freezing. Additional mounding is preferred for freeze protection and aesthetics.

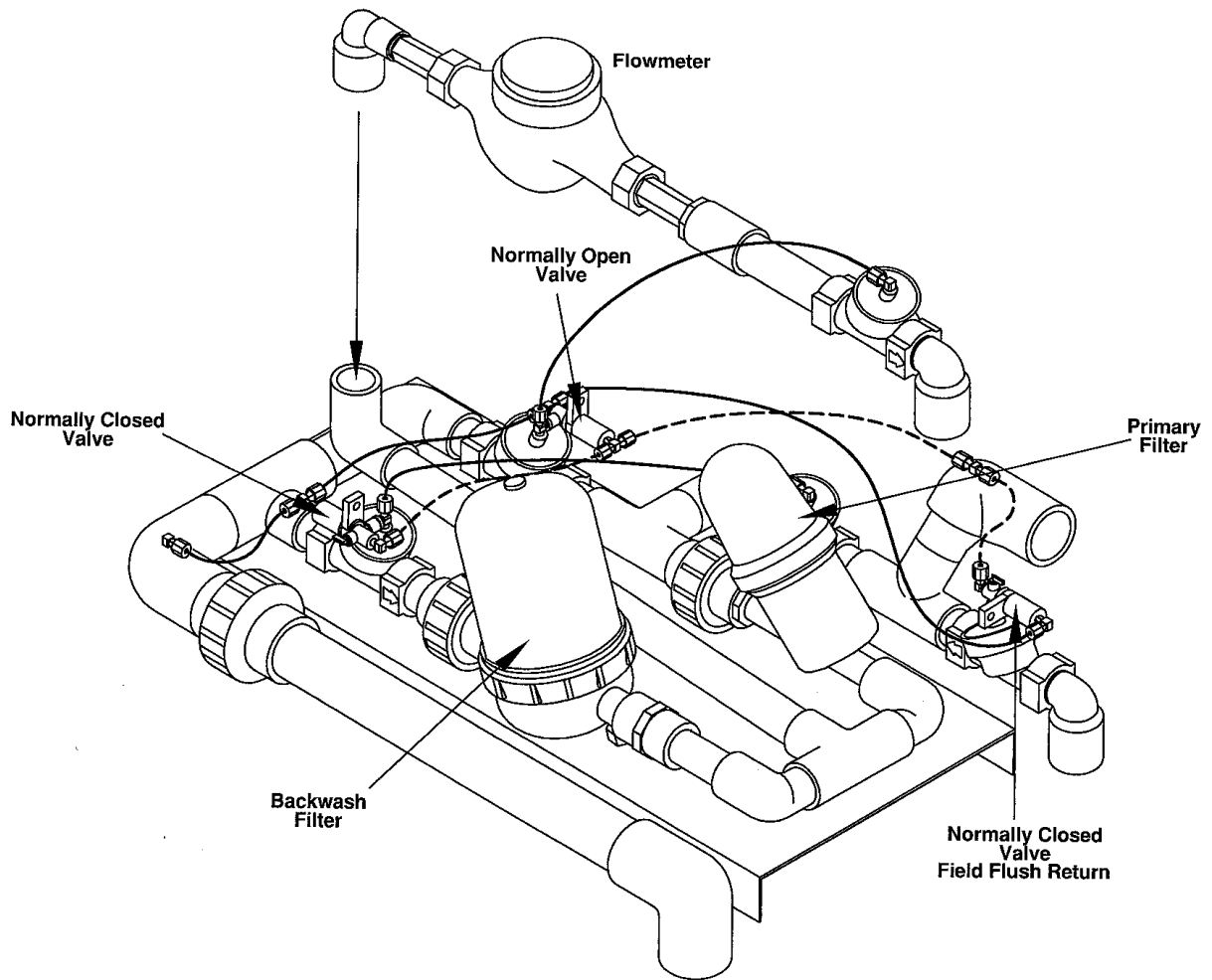

## SEMI-AUTOMATIC FILTRATION UNIT

### SECONDARY EFFLUENT ONLY

#### OPERATION

The Semi-Automatic Filtration Unit is used with secondary effluent only. At the beginning of a pump cycle, effluent is received through the inlet pipe and directed through a normally closed back wash valve, through the backwash filter, then backwards through the smaller primary filter and back to the treatment system. After a prescribed backflush time, valves are sequenced and the effluent is directed through the primary filter and to the drip field(s). When the pump is running and no valves are activated, the effluent is directed to the drip field(s).

Manual operation of the valves may be achieved by operating the manual operator on the valve itself or by electrically activating any valve with the (H-O-A) switch provided on the control. To Electrically activate the valve, place the (H-O-A) switch provided in the (H) or hand position.

In the event the backwash filter becomes clogged due to reduced effluent water quality or an extended period between maintenance events, sufficient water will **not** discharge through this filter to backwash the primary filter. The discharge from the primary filter will be reduced generating a high level alarm thus a call for maintenance.

\*\*\*Pump must NOT be installed with a weep hole.

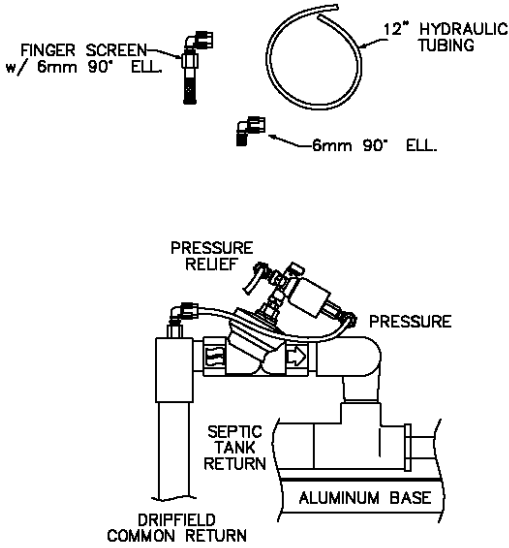

RETURN PRESSURE ASSEMBLY  
NTS

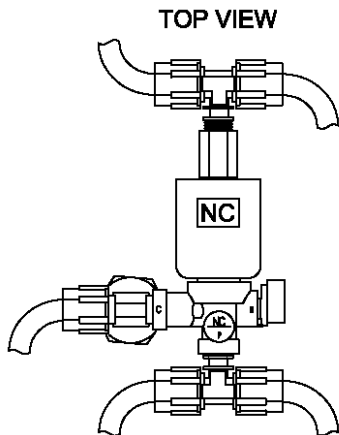

**SOLENOID FOR NORMALLY  
CLOSED DIAPHRAGM VALVE**

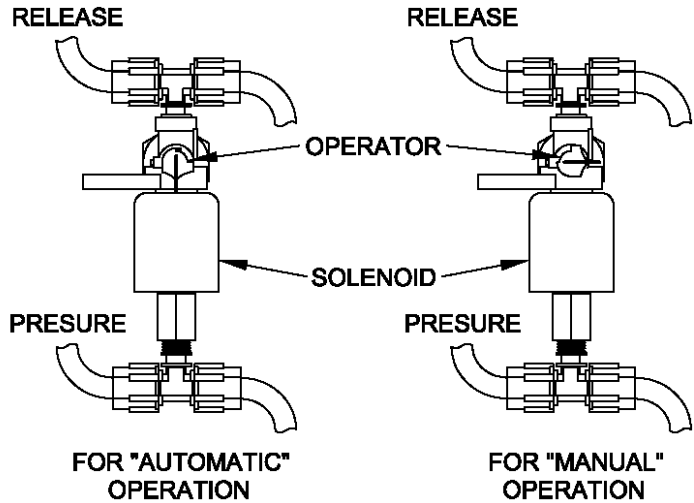

**SOLENOID FOR NORMALLY  
OPEN DIAPHRAGM VALVE**

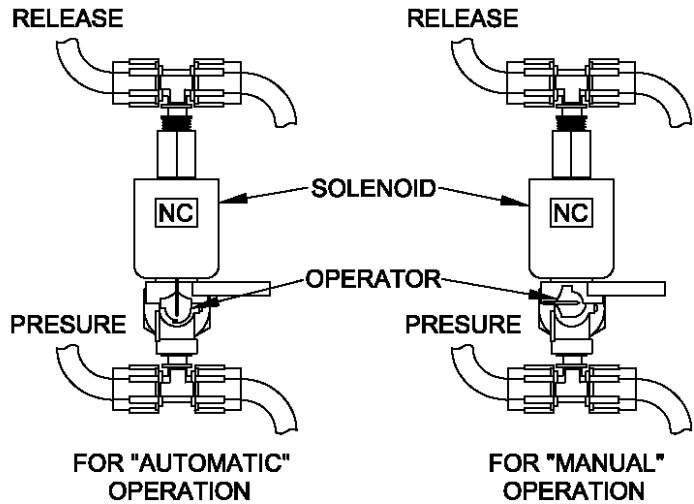

**NOTES:**

1. The hydraulic unit above is shown in an explosion view on the next page.
2. The "normally closed" zone valves and zone return valve have "normally open" solenoids (typically unmarked). These valves are supplied pressure through the solenoid which, when not activated, places pressure on the diaphragm.
3. The "normally open" supply valves have "normally closed" solenoids. The pressure is supplied through the operator and tee connection. With the solenoid not activated, pressure bleeds off the diaphragm.
4. In the event the drip zones are over 10 feet in vertical elevation above the hydraulic unit, install a "return pressure assembly". The assembly is to be used to prevent the return line from draining after or during each dose. Remove the zone return connection and reinstall a short 1" nipple in the return valve. Install assembly as shown to the right. The hydraulic tubing providing pressure for the rest of the unit must be plugged and the new tubing from the assembly connected to the pressure side of the solenoid.

## Installation Procedure Summary

1. Prepare field location for installation.
2. Set treatment and pump tanks.
3. Dig header ditch for field manifold.
4. Install dripper tubing.
5. Install loops (flex tubing).
6. Dig ditches for conveyance lines.
7. Place filter unit and mount control panel.
8. Dry fit pressure lines and field manifolds.
9. Set switch tree in pump tank.
10. Glue all fittings and place valve boxes.
11. Install electrical (and phone line if applicable).
12. Check power supply and power up unit.
13. Provide one day volume of clean water for startup.
14. Pressure check all fittings and lines.
15. Inspection of field and loops.
16. Flush all fields through the air release valves.
17. Set run time for Central Unit.
18. Check setup values against calculated values.
19. Find leaks and repair.
20. Backfill once lines and fields are determined to have no leaks. Back filling is to be controlled to prevent the damaging of pipes or fittings.
21. Grade and seed site.
22. Log data registers and startup values.

### BLOWER FAIL OPTION

In normal operation, power is supplied from a blower panel to the specified terminals in the Perc-Rite® control panel. The American Perc-Rite® controller is dependent on that power from the blower for dosing operations. If the blower fails, or is turned off the central unit will stop all automatic dosing functions.

Wires shall run from power terminals of the blower (115V Standard in Perc-Rite® Control) to the terminals of the central unit labeled "DVC" (Direct Voltage Cutout). Polarity is not a factor during this operation but voltage of blower and voltage of cutout relay (115V Supply & Neutral) must match.

## Startup Procedures - *AMERICAN PERC-RITE® DRIP*

This procedure outlines the startup procedures for the drip dispersal field tubing system. The process includes flushing dirt, pipe shavings and other possible construction debris out of the tubing and checking dosing rates in a three step process. First, flush through air release valves, second flush through normal flushing process ( while checking flow rate ), and finally checking final dose flow rate.

### I. System Flushing Air Release Valves Off

- a) Be sure pump chamber is full of clean water. The "Off" float and "Standard Enable" float should be in the up position before starting field flush. Continue to fill tank to "alarm" float. It should take one days' flow of clean water to flush tubing.
- b) Place all toggle switches in the "Off" position and place filter backflush switch in the "Auto" position.
- c) Remove air release valves, attach piece of 1/2" black flex PVC (5' maximum) to 1/2" white PVC with dry coupling (do not glue) and place end to direct discharge away from excavation.
- d) Place filter backflush to filter "BF" position. Backflush for 15 seconds. There should be no flow through the meter. Place filter backflush switch to the "Auto" position.
- e) Switch pump to "Hand" position (effluent should flow through the meter) to allow a manual field flush. After water starts discharging from flex PVC, continue to flush for at least three (3) minutes or until no debris (dirt, PVC shavings, etc.) is noted, whichever is greater.
- f) Place all toggle switches in the "Off" position and place filter backflush switch in the "Auto" position.
- g) Remove black PVC hose, dry, and glue coupling with air release valves.

### II. Field Flush Flow Test

- a) Determine each zone flushing GPM by multiplying the number of lateral connections by 1.6 and adding to the dosing GPM. (see "a" in step III) Resultant should not exceed 12 GPM.
- b) Switch pump to "Hand" position. Place filter backflush switch to "BF" position. Backflush for 15 seconds. Place filter backflush switch to the "Auto" position.
- c) With the pump running, turn switch for the "Zone Return Valve" to "Hand" position to allow a manual flush. After water starts flowing through zone return valve, flush for three (3) minutes, check flow rate and compare with design flushing flow rate.
- d) Place all toggle switches to the "Off" position and place filter backflush switch in the "Auto" position.

### III. Field Dose Flow Test

- a) Determine each design zone dosing Gallons Per Minute (GPM) by the following formula: (If installed as designed refer to calculation sheet.)

$$\frac{\left(\frac{\text{Length of Tubing}}{2}\right) \times 65 \text{ Gallons per Hour}}{60 \text{ Minutes per Hour}} = \text{Gallons per Minute Dosing}$$

- b) Determine dosing flow rate after the zone flush tested. The rate should be close to value calculated in "a" above. Check for leaks and repair as necessary.
- c) With all toggle switches in the "off" position, backflush filter as described above instep II's "b".
- d) Place all switches in the "Auto" position.

### IV. Zone Return Pressure Assembly Flow Test

- a) In some cases when the drip field is around 10' in elevation above the hydraulic unit or when it is significantly above the unit the valve will not close properly and continue to recycle wastewater back to the septic tank. If this condition occurs, follow the following steps.
- b) Remove the zone return connection and reinstall a short 1" nipple in the return valve.
- c) Place the "return pressure assembly" in the return line as per standard detail on page 19.

## V. Timer Adjustment / Automatic Mode

(Note: "Off" and "Timer Enable" float must be up for automatic operation)

- a) Write down gallons from flow meter and target total gallons dose for all Zones.
- b) Place pump in auto position. Adjust timer setting to the approximate calculated value for total gallons per zone (see owners manual). Press "reset" button and hold for 5 seconds. System will automatically backflush filter and the zone. Start stop watch when meter begins flow. Record the time it takes to deliver calculated volume. Adjust timer to that actual time (not the calculated time).
- c) Leave all switches in use to automatic.

## VI. Multiple Zone Adjustments

(Note: "Off" and "Timer Enable" float must be up for automatic operation)



- a) For systems with mechanical valve for multiple zones, follow the dosing and flushing procedures above for each zone.
- b) Write down gallons from flow meter and target total gallons dose for all Zones.

**NOTE: THE HOMEOWNER ASSUMES FULL RESPONSIBILITY FOR CONDITIONS OR MALFUNCTIONS DUE TO CHANGES IN PUMP RUN TIME BY ANYONE OTHER THAN A QUALIFIED SERVICE REPRESENTATIVE.**

### **ADDITIONAL DATA REGISTERS - AMERICAN PERC-RITE® DRIP**

**Data Register** Counters are used to provide delay time for doses and flushing sequences. Counters may be adjusted to start cycles. Registers are field adjustable from the "Logo" unit only. The following table shows which registers can be viewed and adjusted.

### **SETTING CONTROL PARAMETERS**

Press the escape ("ESC") button. You should see the menu that has the Set Parameter listed. Press the  button so that the prompt ( > ) is next to the Set Parameter menu and hit the "OK"  button. Press the  button until you reach the option you wish to change, then change the time and date as necessary. Press OK button until you are back to the menu display. Press ("ESC") button until you are back to the time clock display. The parameters of interest for typical systems include run times and rest times. The American Perc-Rite® Drip System has the following parameters which may be changed;

B04	Backflush Timer	
	TH= 3	Delay before and after filter backflushing.
	L= 15	Backflushing time.
B06	Fieldflush Event Clock	
	D=M	Day of week for field flush event to occur Mon.-Sun..
	ON= 12:02	Time that the event will activate.
	OFF= 12:03	One minute after the ON time. (event is latched)

*NOTES: Up to 3 different settings can be utilized, but only 1 is required.*

*The "D=" display shows 7 dashes one for each day ie "\_M\_W\_ \_S" would indicate Monday, Wednesday, and Saturday.*

B09	Zone Dose Counter	
	LIM=	Counter limit before resetting to "0" (Set to max. 999999)
	CNT=	Current Count
B45	Field Flush Consecutive Counter	
	LIM=	Counter limit before resetting to "0" (Set to max. 999999)
	Cnt=	Current Count

## Order Information

AMERICAN MANUFACTURING COMPANY INC.

P.O. BOX 97, ELKWOOD, VA 22718

1-800-345-3132 Fax: 1-703-754-0058

e-mail: sales@americanonsite.com

web: www.americanonsite.com

**US MAIL: P.O. BOX 549  
ELKWOOD, VA. 22718-0097**

### FREIGHT TERMS

All materials shipped f.o.b. Gainesville, Virginia, via UPS or common carrier. Please consult factory for freight allowances.

### TERMS OF PAYMENT

With an approved credit account, terms are 2% 10 days, net 30 days from date of invoice. A 2% service charge will be applied to all past due invoices. Customer agrees to pay all reasonable collection fees incurred by American Manufacturing. All other orders will be shipped C.O.D. Deposits on some special orders may be required.

### PRODUCT CHANGES

American reserves the right to change prices and modify or redesign any product without notice.

### ERRORS AND CLAIMS

All shipping errors must be reported within 10 days. American Manufacturing will not be responsible for damages, shortages or delays caused by shipping delays. Claims which are the responsibility of American will be expedited immediately, but are limited to credit on or replacement of merchandise involved.

### AMERICAN MANUFACTURING LIMITED WARRANTY

For one year (12 months) after date of purchase, American Manufacturing will repair or replace any product or portion thereof which proves to be defective due to materials or workmanship of American Manufacturing. We reserve the right to repair or replace defective materials at our discretion.

This warranty does not cover the following conditions:

1. Defects or problems caused by improper installation or maintenance of materials.
2. Abuse, neglect or accidental damage of products.
3. Normal maintenance or upkeep of products.
4. Lightning, war, floods, or other acts beyond our control.
5. Misapplication of our products for their designed purpose, or misapplication according to local, state or national codes when in effect.
6. American Manufacturing Company or its representatives are not responsible for labor for replacement of defective parts.

Defective or warranted items must be returned to American or a location designated by AMC. All returns must be accompanied by a return goods authorization number (RGA) supplied by American.

Manufacturing will in no way be responsible for any losses or damages incurred by failure of equipment, parts or service. NOTE: Some states do not allow exclusion of damages, so this may not apply to you.

There are no other warranties written or implied.

---

**INSPECTION AND OPERATION PROCEDURE  
ONSITE DRIP DISPERSAL SYSTEM**

---

NAME: \_\_\_\_\_  
Address: \_\_\_\_\_  
\_\_\_\_\_

DATE: \_\_\_/\_\_\_/\_\_\_  
Time: \_\_\_ : \_\_\_ AM PM

**I. Monitoring Schedule Frequency**

- A. Periodic Inspection \_\_\_\_\_
- B. compile and review (submit) data \_\_\_\_\_

**II. Periodic Inspection**

- A. Field Conditions
  - 1. Walk the field and record any visible wet spots from the drip system.
  - 2. O.K.\_\_\_\_ Repair\_\_\_\_ Comments and remedial action \_\_\_\_\_
  
- B. Controller
  - 1. Lights and manual switch positions.
    - a) Open the control panel and open the lid to the hydraulic unit and pump tank. Make sure all manual switches are in the automatic position. With Microprocessor on, verify power light and run light are on.
    - b) O.K.\_\_\_\_ Comments and remedial action \_\_\_\_\_
  - 2. Microprocessor input: See table in owners manual.
    - a) O.K.\_\_\_\_ Comments and remedial action \_\_\_\_\_
  - 3. Microprocessor output: Verify there is output only when in automatic operation. You may start automatic cycle with "Reset/Stop" button.
    - a) O.K.\_\_\_\_ Comments and remedial action \_\_\_\_\_
  
- C. Pump Tank Liquid Level Float Switches
  - 1. Check liquid level in the pump tank to confirm switch operation.
    - a) If a float is down, its light should be off. Note; High level alarm float requires optional relay installed in control.
  - 2. O.K.\_\_\_\_ Comments and remedial action \_\_\_\_\_
  
- D. Pump and Valve Operation
  - 1. Place pump "Hand-Off-Auto" switch in the "Hand" position to dead head pump against valves. Then open (optional) master valve. Flow meter should not turn indicating there are no leaks.
  - 2. O.K.\_\_\_\_ Comments and remedial action \_\_\_\_\_
  - 3. With the pump running, place each zone valve in the "Hand" (open) position one at a time to check operation. With one zone valve open, flow should register on the flow meter. When the zone valve closes (off position), the flow should stop.
  - 4. O.K.\_\_\_\_ Comments and remedial action \_\_\_\_\_
  - 5. With one zone valve open and flowing, close and reopen (optional) master valve to check operation.
  - 6. O.K.\_\_\_\_ Comments and remedial action \_\_\_\_\_
  - 7. With the pump in the "Hand" position open the filter backwash valve for filter one and two for ten seconds then close. There should be no flow registering in the flow meter and you should hear the valves open and close. The backwash return valve diaphragm will rise then lower during backflush.
  - 8. O.K.\_\_\_\_ Comments and remedial action \_\_\_\_\_
  - 9. Return all switches to the automatic position
  
- E. Hydraulic Unit
  - 1. Examine one filter and clean all filters as needed.
  - 2. Examine all hydraulic components for leaks, tubing crimps and other problems.
  - 3. O.K.\_\_\_\_ Comments and remedial action \_\_\_\_\_

### III. Annual Inspections (Includes Periodic Inspection)

#### A. Extended Check - Zone Dose Rates

1. Open the air release valve boxes and inspect. Make sure they close during the dose with no water leak after air is evacuated.
2. O.K. \_\_\_ Comments and remedial action \_\_\_\_\_
3. Determine how many zones are in operation and the installed flow rates from the installation records.
4. O.K. \_\_\_ Comments and remedial action \_\_\_\_\_
5. With the pump in the "Hand" position, select the first zone by placing the zone valve switch in the "Hand" position. After pressurization time, check flow rates by reading the flow meter for a timed minute. Repeat for all zones. If flow varies by more than 10% from original flow rates, reset flow rates.
6. O.K. \_\_\_ Comments and remedial action \_\_\_\_\_
7. After the final zone is checked, place the "Zone Return" valve in the "Hand" position while the "Zone Valve" is still in the "Hand" position and verify that the flow rate increased to provide field flushing.
8. O.K. \_\_\_ Comments and remedial action \_\_\_\_\_
9. Return appropriate switches to the automatic position.
10. O.K. \_\_\_ Comments and remedial action \_\_\_\_\_
11. Press reset button for 5 seconds and check automatic zone dosing time.
12. O.K. \_\_\_ Comments and remedial action \_\_\_\_\_

#### B. Tanks & Pumps

1. Examine and clean effluent screens, filters, and floats as needed.
2. O.K. \_\_\_ Comments and remedial action \_\_\_\_\_

#### C. Measure solids level in all tanks

1. Septic tank      Tank Depth \_\_\_\_\_ Sludge Depth \_\_\_\_\_
2. Settling Tank      Tank Depth \_\_\_\_\_ Sludge Depth \_\_\_\_\_
3. Dose Tank Tank Depth \_\_\_\_\_ Sludge Depth \_\_\_\_\_
  - a) Sludge pumping required    Yes \_\_\_ No \_\_\_

### IV. Reporting

- A. Provide summary report to customer showing gallon flow to each field along with pertinent operating information and suggestions.
- B. Provide signed and dated inspection report to customer file and regulatory agency as needed.
- C. Have records available and be prepared to discuss operation and maintenance specifics with customer personnel.

V. **Operator Signature** \_\_\_\_\_ **Date:** \_\_\_\_\_

Perc Rite® Dealers are authorized to reproduce forms in this manual as needed for each site. Additional comments (use back of copy if necessary):

# ***AMERICAN MANUFACTURING COMPANY, INC.***

INNOVATIVE TECHNOLOGY FOR THE ENVIRONMENTAL AGE

## ***CATALOG PRODUCTS***

American Manufacturing Company, Inc. manufactures many specialty On-Site Wastewater products including the Bull Run<sup>R</sup> Valve, Dial-A-Flow<sup>TM</sup>, Distribution Boxes, accessories and Controls. American also supplies as an Original Equipment Manufacturer (OEM) many other products unique to the On-Site Industry.

The American On-Site Products Catalog is used throughout the industry not only for purchasing but for reference and education. If an individual desires a product not shown in the catalog, a toll free call to our 800 number will normally result in getting information about the desired product.

## ***CONTROLS***

American Manufacturing becomes involved with the entire operation of the system whether potable water, process water, or wastewater. American has staff Professional Engineers, designers, soil scientists, and trained sales people with state-of-the-art experience in control systems.

Our objective is to provide the most practical, economical, and efficient control device for fluid handling. We inventory many standard application controls and are able to manufacture special application panels in a very timely manner due to our modular design and manufacturing methods.

## ***PACKAGES***

American Manufacturing Company, Inc. manufactures many specialty On-Site Wastewater system packages including Recirculation Sand Filter components, pump station equipment, and State-Of-The-Art ***American "PERC-RITE<sup>®</sup>" Drip*** units incorporating automatic field flushing, disc filter backflushing, and pressure compensating emitters.

**1-800-345-3132**

**[www.americanonsite.com](http://www.americanonsite.com)**