



AMERICAN ONSITE PRODUCTS

ACCESSORIES

SLUDGE JUDGE



SWEET AIR



CONSTANT HEAD PERMEAMETER

The Compact Constant Head Permeameter is an advanced portable piece of field equipment for measuring saturated hydraulic conductivity (Ksat) of the vadose (unsaturated) zone in the natural soil. The standard unit shown here can be used to measure Ksat from the soil surface to shallow depths. Depth of measurement can be increased to 4 meters using an other devices such as listed below.

CONSTANT HEAD PERMEAMETER

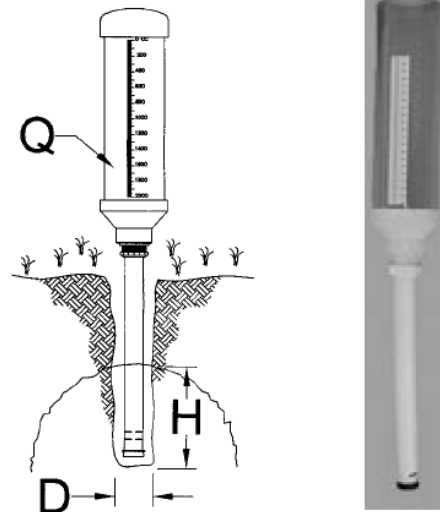

PERMEAMETER

This placement, slow rate, inverted constant head permeameter provides an alternative device to estimate the hydraulic conductivity of soils for shallow installations.

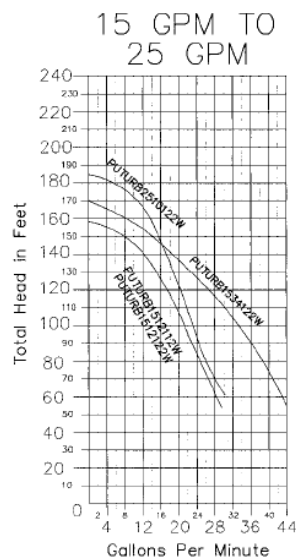

ITEM

PUTURB1512112W
 PUTURB1512122W
 PUTURB1534122W
 PUTURB2510122W
 PERMEAMETER
 SLUDGEJUDGE
 SLUDGEJUDGEBRSH
 SLUDGEJUDGECASE
 SLUDGEJUDGEEXT
 SLUDGEJUDGE-EXT
 SLUDGEJUDGEULTR
 SWEETAIR
 SWEETAIR4
 SWEETAIR490
 SWEETAIRCAP

DESCRIPTION

15 GPM TURBINE 1/2 HP, 1PH, 115V, 2 WIRE
 15 GPM TURBINE 1/2 HP, 1PH, 230V, 2 WIRE
 15 GPM TURBINE 3/4 HP, 1PH, 230V, 2 WIRE
 25 GPM TURBINE 1 HP, 1PH, 230V, 2 WIRE
 PERMEAMETER CLEAR 4"
 SLUDGE JUDGE DEPTH RECORDER
 SLUDGE JUDGE BRUSH
 SLUDGE JUDGE CASE
 SLUDGE JUDGE MIDDLE EXTENSION
 SLUDGE JUDGE MIDDLE/EXTENSION SECTION
 SLUDGE JUDGE ULTRA
 SWEET AIR FILTER 3" W/ CAP
 SWEET AIR FILTER 4"
 SWEET AIR FILTER 90 ELL 4"
 SWEET AIR OVERFLOW DOME CAP 3"