

PERC-RITE® WASTEWATER DRIP DISPERSAL SYSTEMS

DESIGNERS' GUIDE

Appendices

1. PERC-RITE® DRIP SYSTEM CONTROL
2. SEQUENCE OF OPERATION
3. PERC-RITE® DRIP SYSTEM FILTER SYSTEM
4. STANDARD MODEL NUMBERS & DESCRIPTION
5. SPECIFICATIONS
6. DESIGN EXAMPLE
 EXAMPLE OPERATIONAL SPECIFICATION
 EXAMPLE SITE LAYOUT
 EXAMPLE HYDRAULIC PROFILE
 EXAMPLE WORKSHEET
7. STANDARD DETAILS
8. GLOSSARY
9. REFERENCES
10. WARRANTY

The "state of the art" controller is enclosed in an outdoor electrical control box located near and connected to the hydraulic unit. The control panel uses 230-volt power and the microprocessor has 120V and 24V AC inputs and relay outputs for automatic operation of the **PERC-RITE® SEPTIC DRIP SYSTEM**. When in the "Hand" or "Off" position, the manual switches (Hand-Off-Auto) on the door of the control panel completely bypass the microprocessor. The "Hand" position will allow manual operation of the entire system in the event of a microprocessor failure.

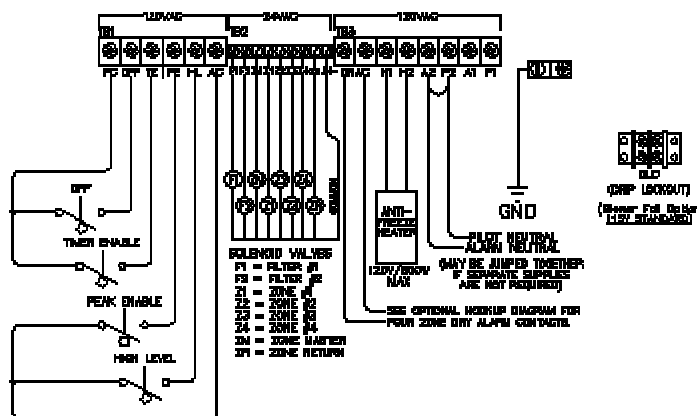
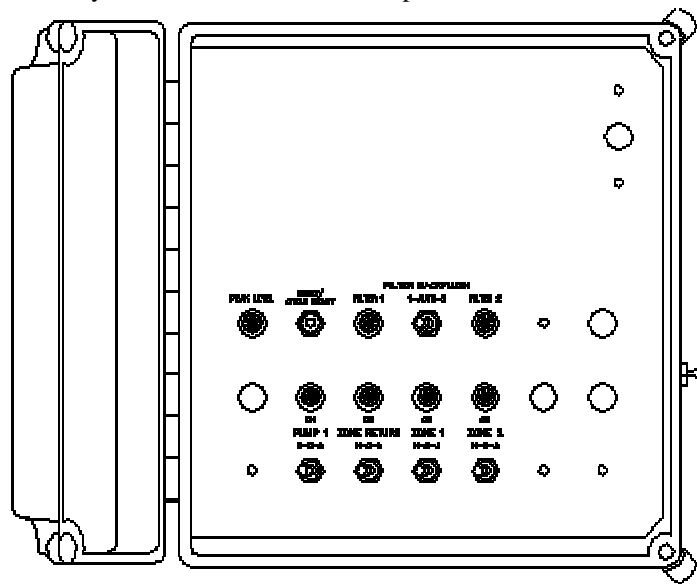

SEQUENCE OF OPERATION PERC-RITE® DRIP SYSTEM

The pump control panel is equipped with four float switches to control the timed doses to be discharged. The four float switches, "Redundant Off", "Standard Dose Enable", "Peak Dose Enable" (optional), and "High Level" function as follows:

Redundant Off - The water level must be high enough to overcome the "Redundant Off" (first & bottom) float in order for the pump to be permitted to run.

Standard Dose Enable - When the water level rises high enough to overcome the "Standard Dose Enable" (second) float and the time clock has timed out the preset time delay of 180 minutes (rest between dosing cycles for two zone designs) the pump will activate and the lead zone is dosed. The pump will continue to run for the length of time as adjusted on the pump run timer and then shut off. The pump will remain off until the internal time clock again times out the preset time delay (180 minutes) after which the pump will activate (as long as the "Standard Dose Enable" float is still up) and will run until the pump run timer finishes timing out. This process will repeat until the water level drops below the "Standard Dose Enable" float and the pump run timer has timed out. The rest time automatically varies with the number of Zones.

Peak Dose Enable - The control system will be equipped with a "Peak Dose Enable" circuit to manage peak flows and excess water use. If the rising water level activates the "Peak Dose Enable" (third) float, the "Pump - Off - Pump & Alarm" switch is set to "Pump", and the preset time delay has exceeded 108 minutes ("Peak Dose Enable" rest between cycles for two zone designs), the lead zone will be dosed. When the peak circuit has been deactivated the normal pumping cycle will resume. If the rising water level activates the "Peak Dose Enable" (third) float, the "Pump - Off - Pump & Alarm" switch is set to "Pump & Alarm", and the preset time delay has exceeded 108 minutes ("Peak Dose Enable" rest between cycles for two zone designs), the lead zone will be dosed and the "Peak Dose Enable" alarm will be activated. The audio portion of the alarm may be silenced by pressing the Test-Normal-Silence switch to the silence position. When the "Peak Dose Enable" float has returned to the down position the alarm will be deactivated and the normal pumping cycle will resume. The rest time automatically varies with the number of Zones.

High Level - If the water level rises enough to overcome the "High Level" (fourth) float, the audiovisual alarm will activate. The audio portion of the alarm may be silenced by pressing the Test-Normal-Silence switch (located on the outside of the control panel) to the silence position. The alarm circuit will auto reset when the "High Level" float returns to its normal (down) position. The high level alarm float is a wide angle float in order to latch the alarm signal.

PRIMARY OR SEPTIC FILTER MODULE

The submersible pump delivers unfiltered effluent to each filter. The filter backflushing schedule is triggered at the beginning of each dose cycle. One filter valve closes, thus blocking the flow of unfiltered effluent to that filter. After a short delay, the other flushing valve opens, thereby backflushing the unused filter. The accumulated impurities discharge back into the pretreatment unit. The backflush procedure lasts approximately fifteen seconds. Effluent will then be pumped through clean disc filters, then through the flow meter and finally through the outlet manifold to the drip field supply line. During extended dose times the disc filters will again be backwashed to assure optimum operation.

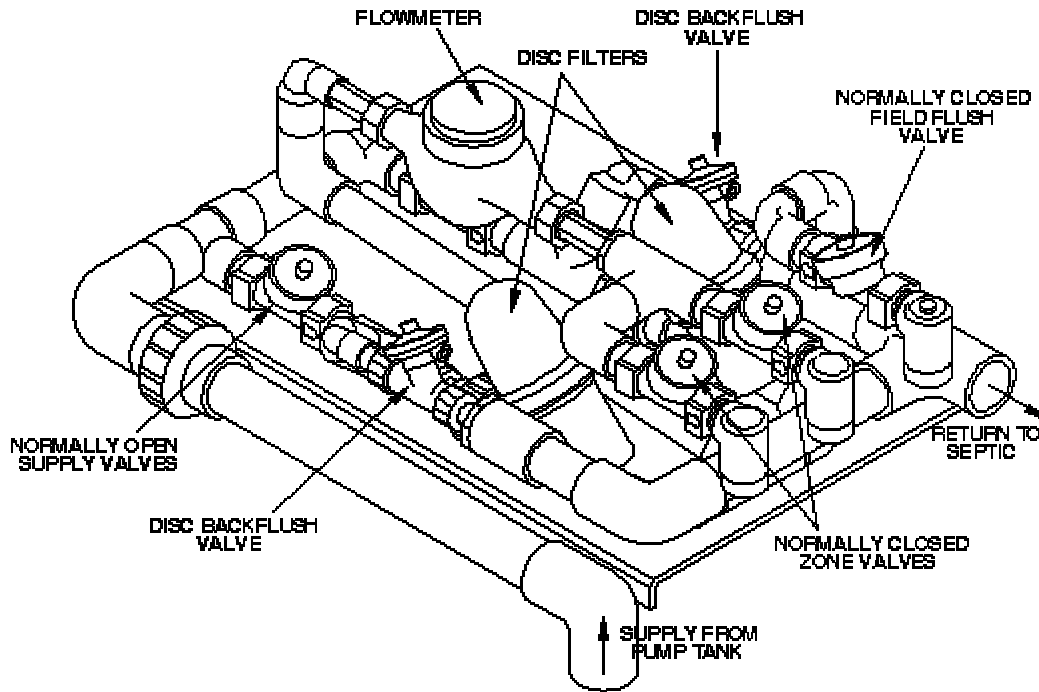

QUALITY MONITORING SECONDARY FILTER MODULE

The submersible pump delivers unfiltered effluent to the primary filter. The filter back flushing schedule is triggered at the beginning of each dose cycle. One filter valve closes and the other filter valve opens, thereby back flushing the primary filter with filtrate from the back flush manual clean filter. The accumulated impurities discharge back into the pretreatment unit. The back flush procedure lasts approximately fifteen seconds then the back flushing valve closes. Only after the primary filter has completed its back flushing cycle will the effluent then be pumped through the cleaned disc filter, then through the flow meter and finally through the outlet manifold to the drip field supply line. In the event the backwash filter accumulates excess particles, a high level alarm will result. During each service event the backwash filter should be cleaned.

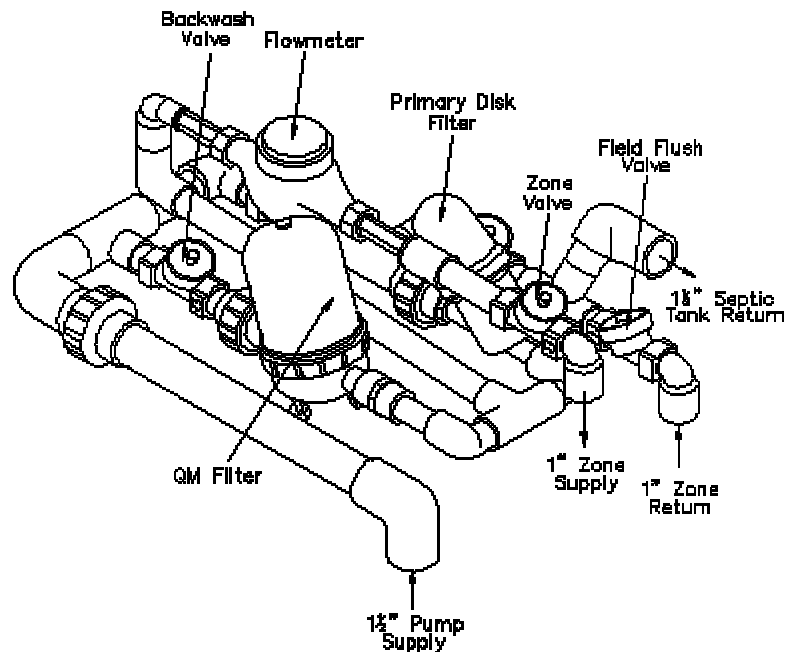

DESIGN SUBMITTAL
AMERICAN "PERC-RITE"[®]

WASTEWATER DRIP SYSTEMS
2 ZONE OR 4 ZONE -- SIMPLEX or DUPLEX
PATENT NO. 5,200,065

CUST. NAME: _____ DATE: _____

JOB NAME: _____ JOB NO.: _____

CONTENTS

<u>Sheet</u>	<u>Description</u>	<u>Page</u>
1	COVER PAGE	1
2	ELECTRICAL & OPERATIONAL SPECIFICATION	2
3	DESIGNERS' WORKSHEET	3
4	SYSTEM LAYOUT	4
5	ZONE DETAIL	5
6	HYDRAULIC PROFILE	6
7	STANDARD DETAILS	7
8	SPECIFICATIONS	8

SPECIAL INSTRUCTIONS:

EXAMPLE

ELECTRICAL AND OPERATIONAL SPECIFICATIONS

CUST. NAME: CUSTOMER 1
 ADDRESS: ANYWHERE
HOMETOWN, USA

JOB NAME: SAMPLE 1
 JOB NUMBER: SAM 022002
 ADDRESS: _____
"SAME"

PERMIT INFO: HEALTH DEPT.
HOMETOWN, USA

DESIGNER NAME: DESIGNER 1
 ADDRESS: ANYPLACE
HOWETOWN, USA

SYSTEM INFORMATION

GPD 600
 MAX GPM 10
 NO. ZONES 2
 ZONE DETAIL NO. Z233
 DOSES PER DAY 4

<u>MODEL NUMBER</u>		<u>RUN TIME</u>
1. ASD152-S122	<u>X</u>	<u>7.66</u>
2. ASD151-S122**	_____	_____
3. ASD153-S124	_____	_____
4. ASD154-S124	_____	_____

Check the model number that has the number of zones per the zone detail. Record the run time from the Run Time Table.

Model **ASD151-S122 has a master valve and remote zone valves for specifying when pumping downhill.

ELECTRICAL CIRCUIT REQUIREMENTS

1. PUMP 1/2 HP, 115V, 1 PHASE
2. CONTROL 15 AMP, 115V, 1 PHASE
3. OTHER _____

OPTIONS

Return Pressure Assembly _____ (Y)
 Use pressure assembly anytime the lift from filter unit to drip field exceeds 10 feet.

Drain Down Assembly X _____ (Y)
 Blower Cut-out _____ (Y)
 24" Riser 24 " long X _____ (Y)
 24" Lid X _____ (Y)
 30" Riser _____ " long _____ (Y)
 30" Lid _____ (Y)

Tubing Rolls (1000') _____

SPECIAL INSTRUCTIONS

(use back if necessary)

AUTHORIZED SIGNATURE

_____ Date: _____

() Owner (X) Agent

NOTE: ATTACHED SHOULD BE A ZONE DETAIL

AMERICAN USE ONLY

Sales Order Number _____
 File No. _____
 SBT Input BY _____



AMERICAN
 Manufacturing Company, Inc.
 www.americanonsite.com

AMERICAN MANUFACTURING

PERC-RITE® WORKSHEET - Dispersal system design worksheet for residential systems.

JOB NAME: SAMPLE 1

JOB NUMBER: SAM022002

	Y N (X) () (X) ()	Are supply and return pipes 1"? Is the lift from the pump to the Filter Unit < 8' and the distance < 30' with 1-1/2" pipe?
1	<u>600</u> gpd	Quantity of wastewater to disperse.
2	<u>.34</u> gpd/LF	Tubing loading rate required to treat and disperse wastewater. Reference Soil Loading Rate Table. (Area Rate X 2)
3	<u>1765</u> LF Tubing	Required total linear feet of tubing to treat and disperse wastewater. (#1 / #2 = #3)
4	<u>233</u> Zone Detail	Standard Zone detail description indicating number of zones, laterals, and runs per zone.
5	<u>1800</u> LF Total	Total linear feet of tubing provided to disperse wastewater. Total number of runs times the length of run along contour. Reference Standard Detail Zone Table.
6	<u>900</u> LF/Zone	Total linear feet per zone. (#5 / Number of Zones)
7	<u>4.9</u> gpm dose <u>10</u> gpm FF	Dosing flow rate. See "dosing & FF flow table." Field flush (FF) flow rate. See dosing & FF flow table.
8	<u>290</u> Supply LF	Length of run between hydraulic unit and farthest zone.
9	<u>32</u> Lift Ft.	Vertical lift from off level in the pump chamber and highest zone elevation.
10	Will zone flush? Y N (X) ()	Reference "lift and run table" for pump capacity determined by the length of run to the farthest field and the number of laterals. For 1" supply and return only.

DESIGNER 1
DESIGNER'S NAME:

Designer 1
Signature

2/20/02
Date

DESIGN EXAMPLE

The proposed use is a four bedroom single family home sized at 150 gallons per bedroom per day or 600 gpd peak flow. The available area is 100' on contour by 72' or 7200 ft². The county requires a 100% future contingency area, so one half, or 36' x 100' is available for installation. The most restrictive soils from the surface to the limitation has a silty clay loam texture with moderate, medium to fine structure. With an 8" installation depth, the separation to limitation is at the minimum for septic tank effluent, however the site has attributes such as an upland topographic landscape position, a strong slope, convex topography and healthy turf cover. No rock was observed to 4 feet. The site area loading rate would be 600 gpd / 3600 ft² or .17 gal/ft²/day.

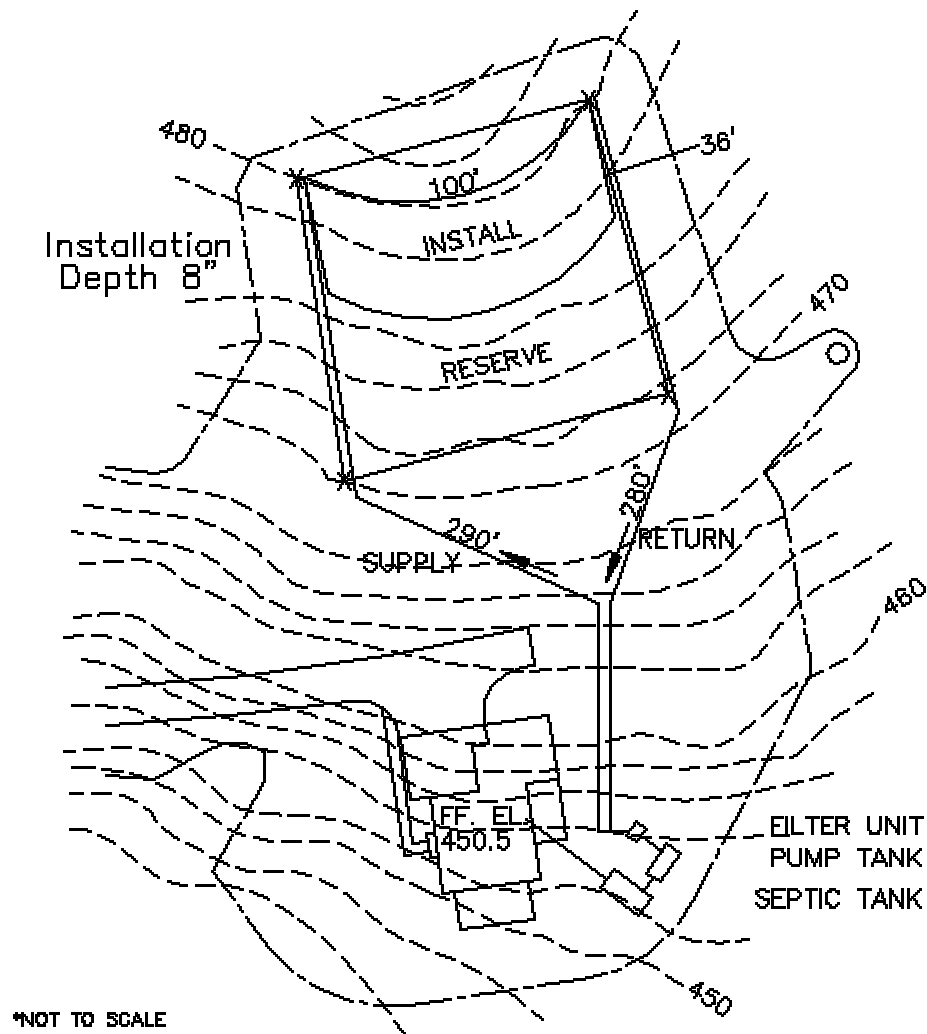

SITE CONDITION and ZONE DETAIL SELECTION

600 GALLONS PER DAY
 .17 GPD / SQ.FT. SOIL LOADING RATE
 100' ALONG CONTOUR

From the loading rate table determine the tubing-loading rate. A .17 gpd/sq.ft. Equals .34 gpd/LF. Therefore the total linear feet of tubing required is $600 / .34 = 1765$ LF required. This is the only calculation required.

See the *Zone Detail Table* and determine the detail for a system width of 100 ft you need at least 18 runs. Match the number of runs across contour that can be installed. From the table select the zone detail for the site. The following zone detail meets the site requirements.

<u>Z</u>	<u>2</u>	<u>Z</u>	<u>Z</u>
Z = Zone	# Zones	# Laterals	# Runs/Lat

ZONE DETAIL SELECTION

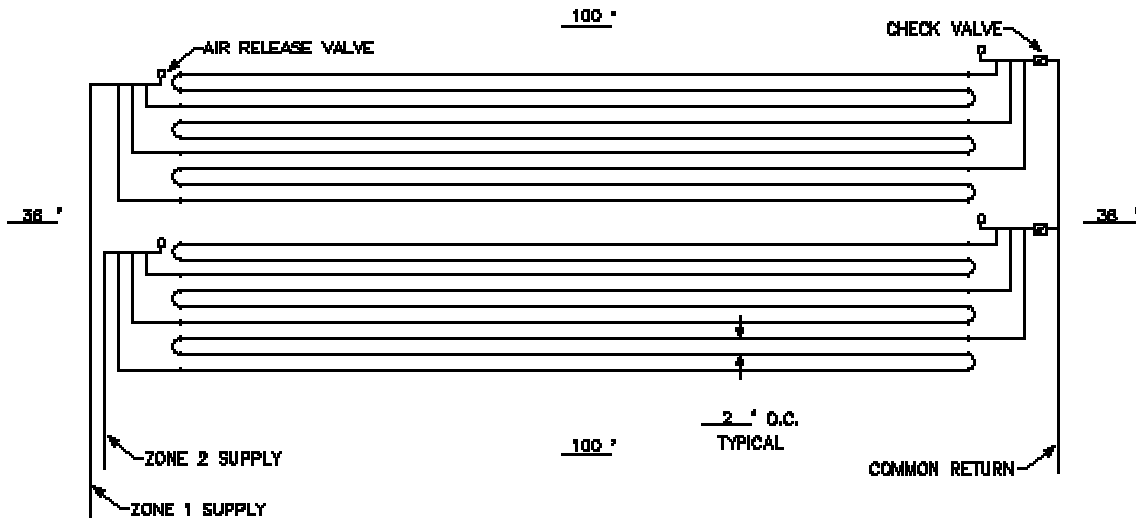

SPECIFICATIONS

The **PERC-RITE® DRIP SYSTEM** shall be installed with a water tight septic tank with at grade access and a water tight pump tank with a minimum 24" diameter light weight and lockable lid. The pump tank shall be of the same volume and the septic tank required for the facility to be serviced.

The **PERC-RITE® DRIP SYSTEM CONTROLLER** shall be a U/L listed control panel activated by level sensing devices (standard mercury or mechanical differential float switches) located in a dosing tank downstream from the pretreatment process or processes. When activated by the rising level of effluent in the dosing tank, the controller will enable the disposal cycle. The system controller on a time clock basis shall pump the effluent through the filter module and then to final drip dispersal. The controller shall be manufactured by American Manufacturing Co. Inc.

The **FILTER MODULE** shall include Disc filters, automatic control valves, solenoid activated diaphragm valves, flow meter and shall be assembled in a heated enclosure and provided with a labeled wire harness for easy connection the the control panel. The filter module shall be manufactured by American Manufacturing Co. Inc.

The **PUMP SYSTEM** - The pump, Cool Guide™ , float switches for level indication are provided for installation into the pump tank. The pump is a turbine 15 gpm pump and will be suitable for most residential installation. Reference lift and run table for pumping limits. The pump system shall be supplied by American Manufacturing Co. Inc.

The **DRIPPER TUBING** shall be pressure compensating dripperline for wastewater. The tubing shall deliver a nominal 0.65 gallons per hour (+/- 5% flow rate from 7 to 60 psi). The tubing functions as a turbulent flow emitter between 0 and 7 psi, ensuring that the nominal design flow is not exceeded at system start-up. The tubing is polyethylene with a 120 psi pressure rating.

The **TOP FEED MANIFOLD SYSTEM** shall include a top feed supply manifold consisting of an air release valve and the number of 1/2" lateral supply connections equal to the number of laterals in the zone, plus a top feed return manifold consisting of an air release valve, a check valve and the number of 1/2" lateral return connections equal to the number of laterals in the zone. The manifolds shall be installed on sites with drip fields having any slope. Manifolds shall be made with pressure rated schedule 40 PVC and shall be manufactured by American Manufacturing Co. Inc. Patent No. 5,984,574.

AUTOMATIC CONTROL VALVES shall be solenoid activated diaphragm valves. The body and cover shall be reinforced nylon. The metal parts shall be stainless steel, the diaphragm shall be nylon-fabric reinforced poly isoprene. The seals shall be Buna-N. These valves shall operate electrically using hydraulic pressure to open and to close.

GRAVITY PIPING - All gravity piping shall be schedule 40 PVC DWV as a minimum. Fittings shall be Schedule 40 PVC suitable for underground installation. All joints shall be solvent welded with the use of primer and PVC Glue.

NON-DRIPPER LINE PRESSURE PIPING - All non-dripper line pressure piping shall be PVC schedule 40 pressure rated. Rigid piping shall be standard ASTM 1120 for use with solvent welded Schedule 40 fittings. Flex piping shall be schedule 40 PVC flex pipe for use with pressure fittings.

AIR RELEASE VALVES - Air release valves shall be resilient seat "pop-up" type air release valves for use with filtered effluent (nominal filtration size of 115 microns.)

WIRE SPLICES - Field wire splices shall be installed in suitable wire splice pull boxes with waterproof connections for access to splice connections. The boxes shall have structural capacity for in ground installation and light vehicle yard care traffic.

PIPING DISCONNECTS - Piping disconnects shall be PVC schedule 80 unions.

PIPE BEDDING - In ground piping shall be installed according to local codes. Piping shall be installed on original soil or suitably compacted fill or gravel bedded excavations on original soil. Free standing piping shall be schedule 40 PVC and assembled with restrained joints.

~ *GLOSSARY OF TERMS* ~

AREA LOADING RATE: The amount of constituents dispersed in the area where dripper line is to be installed. These materials are described in generally accepted engineering units such as gallons per day per sq. ft. of water and pounds per day per sq. ft. of contaminant (BOD, FOG, Suspended Solids, etc)

CONTROL: Electromechanical Operational interface device used to operate the system. Automatic Control is operation without human physical actions. Manual control operation is the operation of a system which bypasses or is not performed by automatic equipment.

DEMAND ANALYSIS: The determination of the gallons per day a system needs to disperse.

DRAINDOWN: The action of effluent left in the distribution system after the pump shuts off that drains by gravity to the lower lines in the system.

DRIPPER LINE LOADING RATE: The amount of contaminants dispersed by the linear feet of dripper line. This material shall be described in generally accepted engineering units such as gallons per day per linear foot of water and pounds per day per linear foot of contaminant (BOD, FOG, Suspended Solids, etc)

FIELD FLUSHING: The routine maintenance act of cleaning drip tubing by opening the end of a lateral and creating scouring velocities in the same direction of flow in the tubing to remove solids which may plug an emitter.

FLOW EQUALIZATION: Storage of effluent peak flows to provide for even time dosing of drip per lines. It is designed into system by distance between the enable float and the alarm float.

LANDSCAPE LINEAR: That is the gallons per linear foot of the absorption area along the topographic.

LOADING RATES contour, is very important as it addresses natural landscape dispersal of water by gravity away from the adsorption area. Minimize the loading by extending the system contour as the site allows. Landscape linear loading requirements are based on site / soil determination (estimation) of vertical and horizontal subsurface water movement over and through the limitations and will vary with conditions including slope, texture, and depth to limitation. Multi-zoned systems allow for staggering and separation of zones as necessary to minimize hydraulic influences to achieve an appropriate landscape linear loading rate.

LATERAL: One run or a series of runs connected at one end to a supply manifold and the other end connected to a return manifold.

MECHANICAL FILTRATION: Mechanical filtration of the applied effluent to prevent emitter plugging.

MONITORING: Periodic inspection of system for performance.

PRETREATMENT: Conditioning of effluent prior to dispersal by drip system.

RETURN MANIFOLD: The pipe carrying field flushing wastewater from a zone.

RUN: One continuous length of tubing run across contour connected to a supply line or return line or another run.

STANDOFF: The vertical and horizontal separation distance from receiving environmental limitations.

SUPPLY MANIFOLD: The supply pipe feeding a zone to which laterals are connected.

ZONE: A group of laterals dosed at the same time.

References

Additional guidance is available from:

American Manufacturing Company Inc.
Treatment and Dispersal Packages Design Manual

National Onsite Wastewater Recycling Association (NOWRA)
Drip System training manual

American Society for Testing and Materials (ASTM) standard practice:
ASTM D 5879-95 Standard Practice for Surface Characterization for On-Site Systems
ASTM D 5925-96 Standard Practice for Preliminary Sizing and Delineation of Soil
Absorbtion Field for On-Site Septic Systems
ASTM D 5921-96 Standard Practice for Subsurface Site Characterization of Test Pits
for On-Site Septic Systems

EPA Onsite Wastewater Treatment Systems Manual
Office of Water
Office of Research and Development
EOA/625/R-00/008

EPA DRAFT EPA Guidelines for Management of Onsite/Decentralized Wastewater Systems

Notes

WARRANTY

AMERICAN MANUFACTURING LIMITED WARRANTY For one year (12 months) after the date of purchase, American Manufacturing Company, Inc. will repair or replace any product or portion thereof that proves to be defective due to materials or workmanship of American Manufacturing. We reserve the right to repair or replace defective materials at our discretion. This warranty does not cover the following conditions:

1. Defects or problems caused by improper installation or maintenance of materials.
2. Abuse, neglect or accidental damage of products.
3. Normal maintenance or upkeep of products.
4. Lightning, war, floods, or other acts beyond our control.
5. Misapplication of our products for their designed purpose, or misapplication according to local, state or national codes when in effect.

Defective or warranted materials must be returned to us or a place designated by American Manufacturing. All returns must be accompanied by a return authorization number supplied by American Manufacturing.

American Manufacturing will in no way be responsible for any losses or damages incurred by failure of equipment, parts or service. NOTE: Some states do not allow exclusion of damages so this may not apply to you. There are no other warranties written or implied.

AMERICAN MANUFACTURING COMPANY, INC.
Copyright © American Manufacturing Company, Inc., 1998-2000